

STATION 1

INSTRUCTIONS

The figure below shows an assembly of the rear part of a propeller shaft. Sketch in good proportion the exploded view of the assembly and label **four** parts. (10 marks)

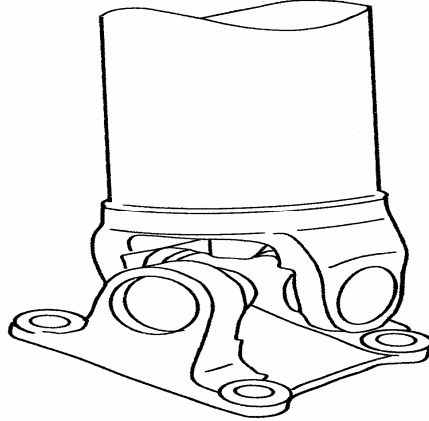

STATION 2

INSTRUCTIONS

Using the tools, equipment and materials provided, make the handle as shown in the figure below. (10 marks)

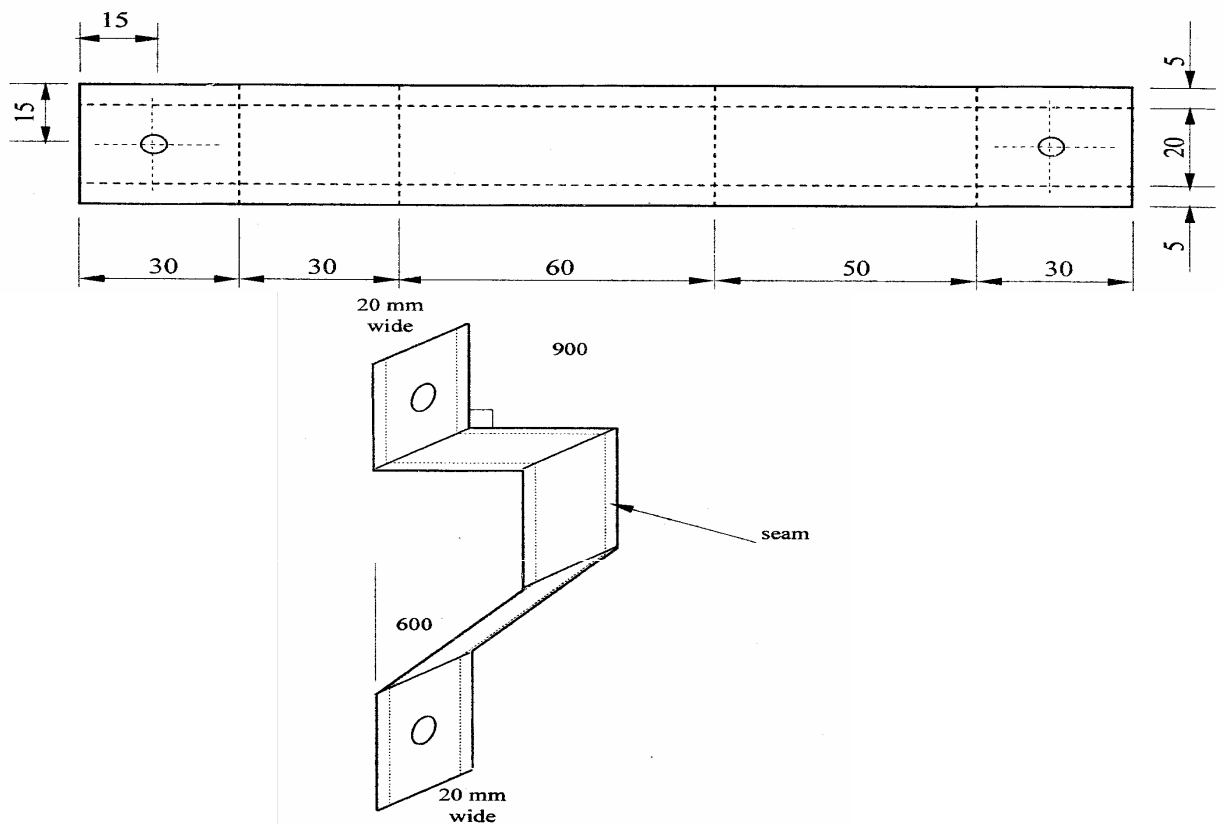

STATION 3

INSTRUCTIONS

Identify the items labelled A to E. State the material each is made of and one use of each item in a motor vehicle. (10 marks)

ITEM	MATERIAL	USE
A		
B		
C		
D		
E		

STATION 4

INSTRUCTIONS

On the ignition coil provided:

- (a) Measure the resistance of:
- (i) primary windings;
 - (ii) secondary windings. (7 marks)
- (b) Test the coil for grounds, record the results in the table below and make relevant conclusion in each case. (3 marks)

MEASUREMENT	CONCLUSION
PRIMARY WINDING R =	
SECONDARY WINDING R =	
TEST FOR GROUNDS	

STATION 5

INSTRUCTIONS

Perform each of the following activities on the distributor provided:

- (a) remove the cap;
- (b) remove the contact breaker points and show them to the examiner;
- (c) state the condition of the contact breaker points;
- (d) replace the contact breaker points;
- (e) set the gap for the points to 0.5mm and let the examiner check your work;
- (f) replace the distributor cap.

(10 marks)

STATION 6

INSTRUCTIONS

Identify the motor vehicle parts labelled **J**, **K**, **L**, **M** and **N**. Name each part, state the vehicle system it belongs to, identify one defect and state one possible cause of the defect. Record your answers in the table below.

(10 marks)

PART	NAME	VEHICLE SYSTEM	DEFECT	POSSIBLE CAUSE
J				
K				
L				
M				
N				

STATION 7

On the single cylinder engine provided:

- (a) Remove the exhaust valve and replace it with the one provided. Let the examiner check your work.
- (b) Measure and record the exhaust valve clearance. (10 marks)

STATION 8

INSTRUCTIONS

- (a) Identify the materials labelled **A** and **B** and state the purpose of each material during brazing.

	MATERIAL	PURPOSE
A.	_____	_____
B.	_____	_____

- (b) (i) Light the gas welding equipment provided and set the torch to an oxidising flame. (Note: the regulator pressures are already set) Let the examiner check your work.
- (ii) Shut down the welding equipment. (10 marks)

STATION 9

INSTRUCTIONS

Carryout the following activities on the engine parts provided:

- (a) Using the vernier calipers, measure the:
- (i) maximum depth of the keyway at the power take-off shaft;
 - (ii) length of the keyway. (2 marks)
- (b) Using the micrometer, measure the:
- (i) diameter of the crankpin;
 - (ii) diameter of the camshaft at the end marked x. (2 marks)
- (c) Count the number of teeth on the crankshaft and camshaft and calculate the gear ratio.

Crankshaft teeth _____

Camshaft teeth _____

Gear ratio _____

(4 marks)

- (d) Demonstrate to the examiner how to check the roundness of the crankshaft main journal using the dial gauge provided. (2 marks)

STATION 10

INSTRUCTIONS

On the multicylinder engine provided:

- (a) Identify **three** components driven by the fan belt.
- (b) Remove the fan belt and show it to the examiner.
- (c) Replace the fan belt. Let the examiner check your work. (10 marks)