

Name Index Number

232/1
PHYSICS
Paper 1
Nov. 2016
2 hours

Candidate's Signature

Date



THE KENYA NATIONAL EXAMINATIONS COUNCIL

Kenya Certificate of Secondary Education

PHYSICS

Paper 1

(THEORY)

2 hours

Instructions to candidates

- (a) Write your name and index number in the spaces provided above.
- (b) Sign and write the date of examination in the spaces provided above.
- (c) This paper consists of **two** sections; **A** and **B**.
- (d) Answer **all** the questions in sections **A** and **B** in the spaces provided.
- (e) **All** workings **must** be clearly shown.
- (f) Silent non programmable electronic calculators may be used.
- (g) This paper consists of **16** printed pages.
- (h) Candidates should check the question paper to ascertain that all the pages are printed as indicated and that no questions are missing.
- (i) Candidates should answer the questions in English.

For Examiner's Use Only				
	Section	Question	Maximum Score	Candidate's Score
	A	1-13	25	
		14	13	
		15	13	
	B	16	10	
		17	11	
		18	08	
		Total Score	80	

SECTION A: (25 marks)

Answer *all* the questions in this section in the spaces provided.

1. State what mechanics as a branch of physics deals with. (1 mark)

.....

.....

.....

2. Figure 1 shows a change in volume of water in a measuring cylinder when an irregular solid is immersed in it.

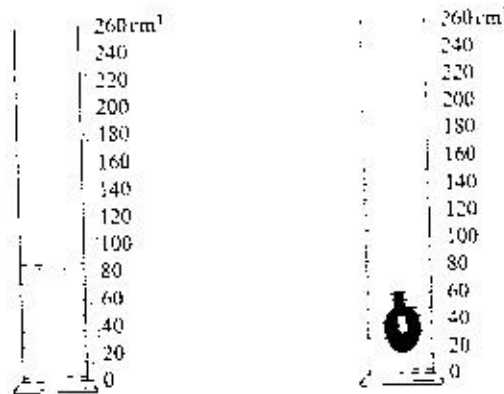

Figure 1

- Given that the mass of the solid is 567 g, determine the density of the solid in g/cm^3 (Give your answers correct to 2 decimal places). (3 marks)

.....

.....

.....

.....

3. When a drop of an organic acid of known volume is dropped on the surface of water in a large trough, it spreads to form a large circular patch. State one assumption made when the size of the molecule of the acid is estimated by determining the area of the patch. (1 mark)

.....

.....

.....

4. **Figure 2(a)** and **2(b)** show capillary tubes inserted in water and mercury respectively.

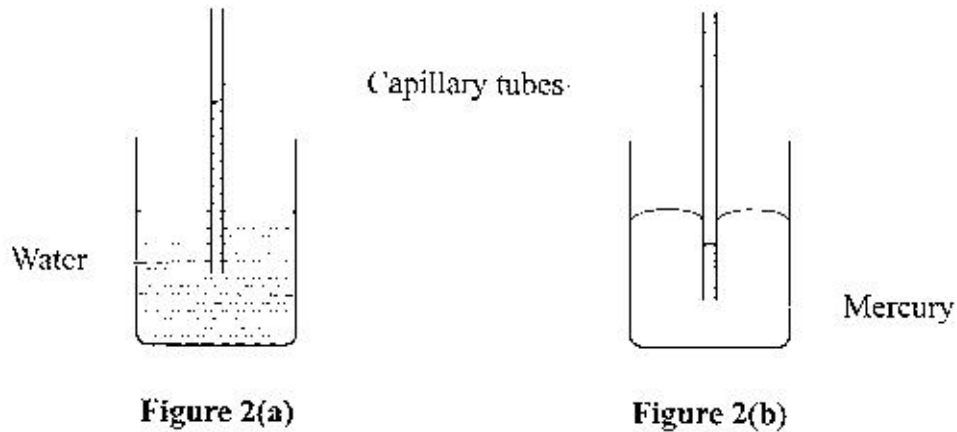

It is observed that in water the meniscus in the capillary tube is higher than the meniscus in the beaker, while in mercury the meniscus in the capillary tube is lower than the meniscus in the beaker. Explain these observations. (3 marks)

.....

.....

.....

.....

.....

.....

.....

5. **Figure 3** shows a hot water bath with metal rods inserted through one of its ends. Some candle wax is fixed at the end of each rod. Use this information to answer questions 5(a) and 5(b).

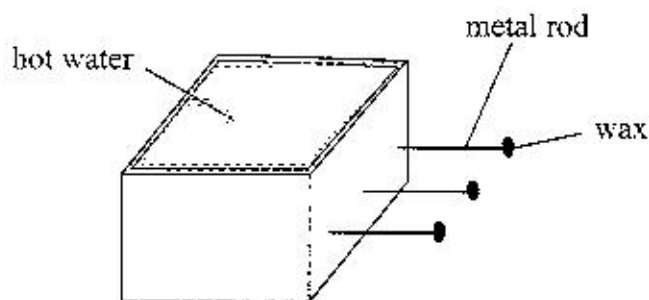

Figure 3

- (a) What property of metals could be tested using this set-up? (1 mark)

.....

.....

.....

.....

- (b) Besides the length of the rods that is kept constant, what else should be kept constant when comparing the property for the different metal rods? (1 mark)

.....

.....

.....

6. Figure 4 shows a uniform light bar resting horizontally on corks floating on water in two beakers A and B.

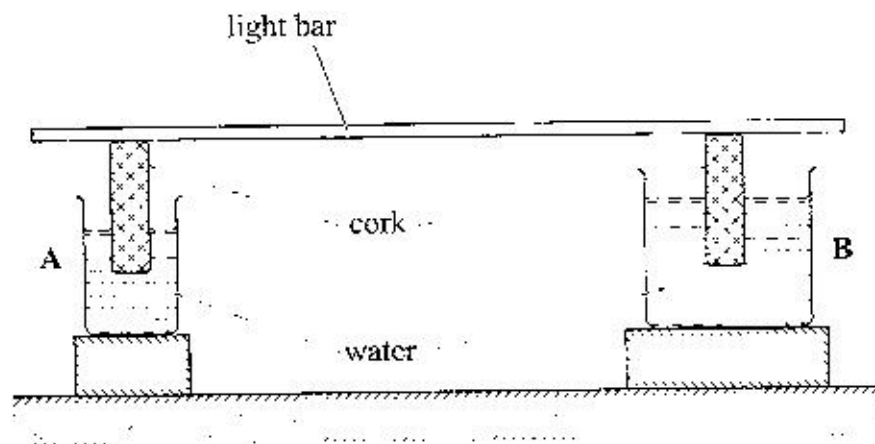

Figure 4

- Explain why the bar tilts towards side A when equal amount of heat is supplied to each beaker. (2 marks)

.....

.....

.....

.....

.....

.....

.....

7. Figure 5 shows an aluminium tube tightly stuck in a steel tube.

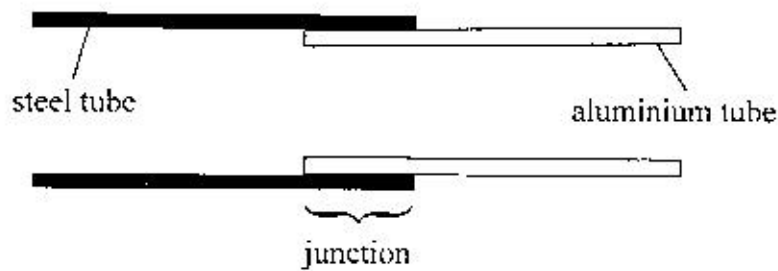

Figure 5

Explain how the two tubes can be separated by applying a temperature change at the junction given that aluminium expands more than steel for the same temperature rise. (2 marks)

.....

.....

.....

.....

.....

8. (a) An aeroplane is moving horizontally through still air at a uniform speed. It is observed that when the speed of the plane is increased, its height above the ground increases. State the reasons for this observation. (1 mark)

.....

.....

.....

.....

.....

- (b) Figure 6 shows parts A, B and C of a glass tube.

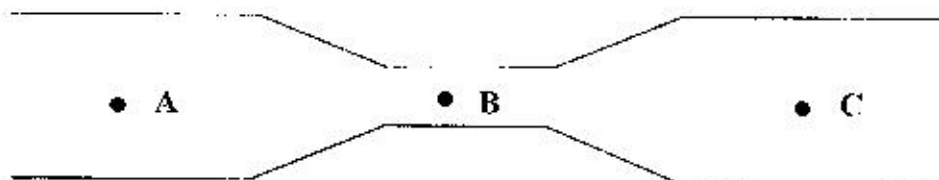

Figure 6

State with a reason the part of the tube in which the pressure will be lowest when air is blown through the tube from A towards C. (2 marks)

.....

.....

.....

.....

.....

.....

9. The three springs shown in **Figure 7** are identical and have negligible weight. The extension produced on the system of springs is 20 cm.

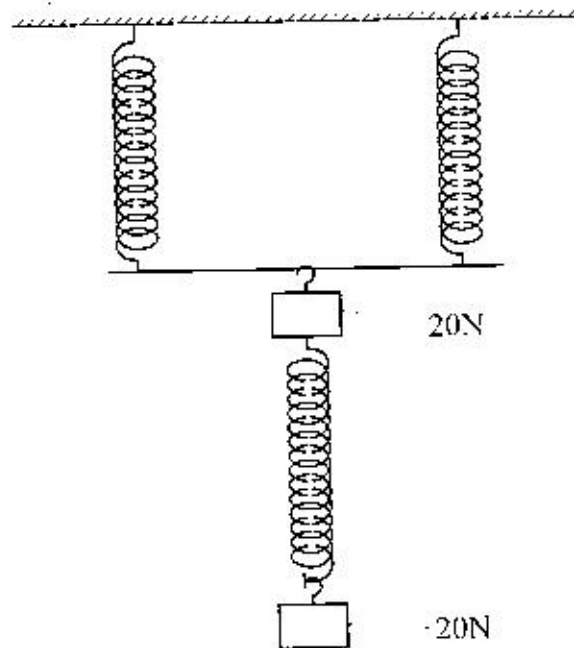

Figure 7

Determine the spring constant of each spring. (2 marks)

.....

.....

.....

.....

.....

10. **Figure 8** shows two cylinders of different cross-sectional areas connected with a tube. The cylinders contain an incompressible fluid and are fitted with pistons of cross-sectional areas 4 cm^2 and 24 cm^2 .

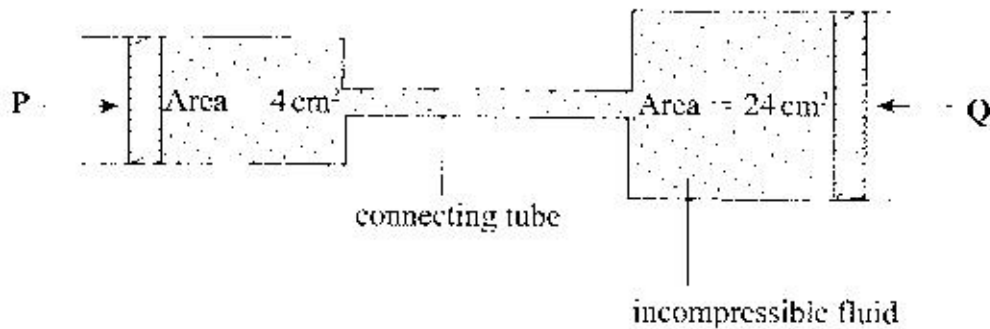

Figure 8

Opposing forces P and Q are applied to the pistons such that the pistons do not move. If the pressure on the smaller piston is 5 N/cm^2 , determine force Q . (2 marks)

.....

.....

.....

.....

.....

11. **Figure 9** shows a uniform cardboard in the shape of a parallelogram.

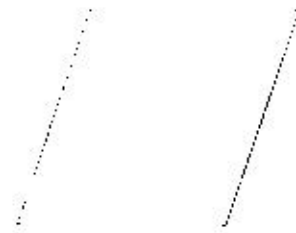

Figure 9

Locate the centre of gravity of the cardboard. (1 mark)

12. State why it is easier to separate water into drops than to separate a solid into smaller pieces. (1 mark)

.....

.....

.....

.....

13. The graph in **Figure 10** shows the velocity of a car in the first 8 seconds as it accelerates from rest along a straight line.

Determine the distance travelled 3.0 seconds after the start.

(2 marks)

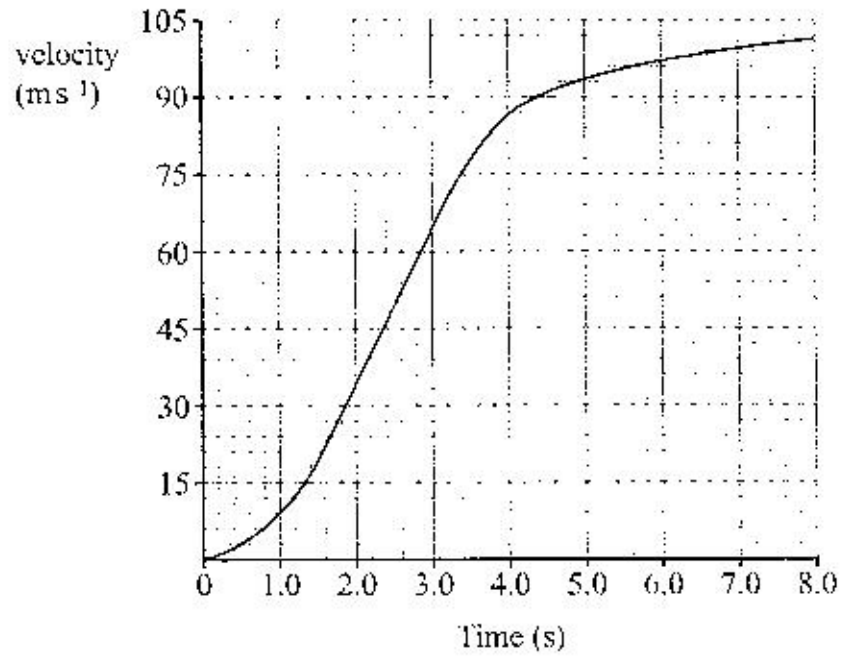

Figure 10

SECTION B: (55 marks)

Answer all the questions in this section in the spaces provided.

14. (a) Explain why it is advisable to use a pressure cooker for cooking at high altitudes. (2 marks)

.....

.....

.....

.....

- (b) Water of mass 3.0 Kg at 20 °C is heated in an electric kettle rated 3.0 KW. The water is heated until it boils at 100 °C. Given that the specific heat capacity of water = 4200 JKg⁻¹ K⁻¹, heat capacity of the kettle = 450 JK⁻¹, specific latent heat of vaporisation of water = 2.3 MJ Kg⁻¹.

Determine:

- (i) the heat absorbed by the water. (3 marks)

.....

.....

.....

.....

.....

- (ii) heat absorbed by the electric kettle. (2 marks)

.....

.....

.....

.....

.....

- (iii) the time taken for the water to boil. (3 marks)

.....

.....

.....

.....

- (iv) how much longer it will take to boil away all the water. (3 marks)

.....

.....

.....

.....

.....

.....

.....

15. (a) State the meaning of the term ideal gas. (1 mark)

.....

.....

.....

- (b) The pressure acting on a gas in a cylinder was changed steadily while the temperature of the gas was maintained constant. The value of volume V of the gas was measured for various values of pressure. The graph in **Figure 11** shows the relation between the pressure P , and the reciprocal of volume, $\frac{1}{V}$.

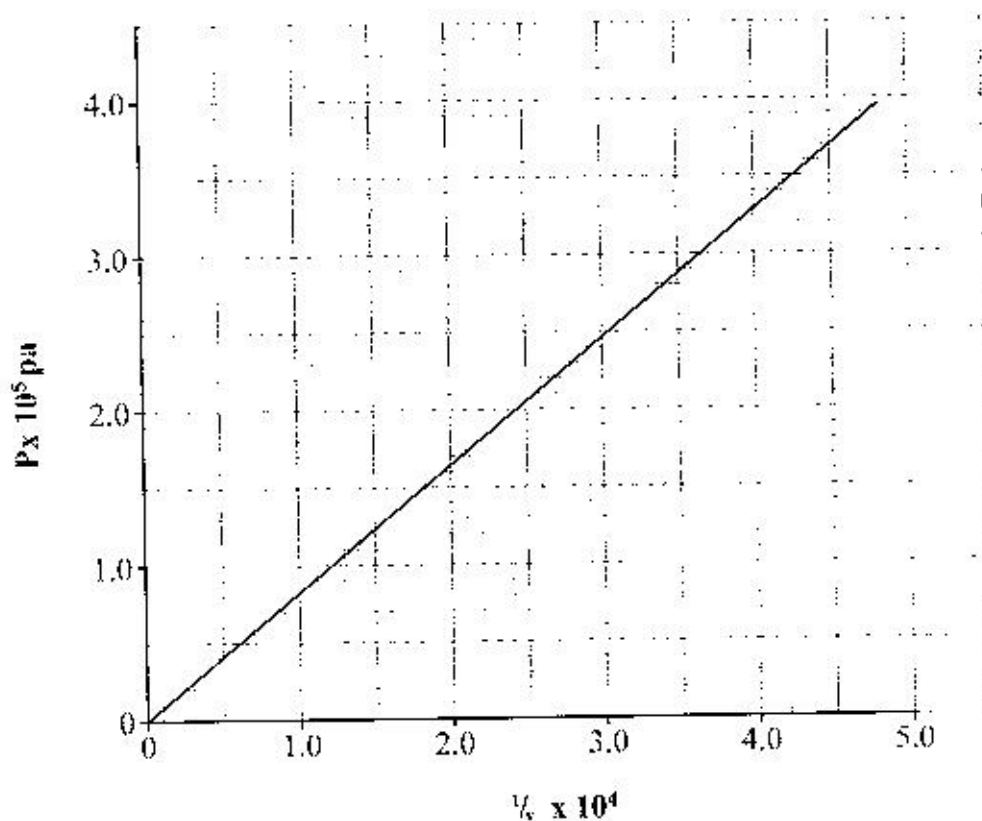

Figure 11

(i) Suggest how the temperature of the gas could be kept constant. (2 marks)

.....
.....
.....
.....

(ii) Given that the relation between the pressure P_1 and the volume, V_1 of the gas is given by $PV = K$, where K is a constant, use the graph to determine the value of K . (4 marks)

.....
.....
.....
.....
.....

(iii) What physical quantity does K represent? (1 mark)

.....
.....
.....

(iv) State **one** precaution you would take when performing such an experiment. (1 mark)

.....
.....

(c) A gas occupies a volume of 4000 litres at a temperature of 37°C and normal atmospheric pressure. Determine the new volume of the gas if it is heated at constant pressure to a temperature of 67°C (Normal atmospheric pressure, $P = 1.01 \times 10^5 \text{ Pa}$). (4 marks)

.....
.....
.....

16. (a) Define the term velocity ratio of a machine. (1 mark)

.....

.....

- (b) **Figure 12** shows part of a hydraulic press. The Plunger is the piston where effort is applied while the Ram piston is the position where the load is applied. The Plunger has cross-section area $a \text{ m}^2$ while the Ram piston has cross-section, $A \text{ m}^2$.

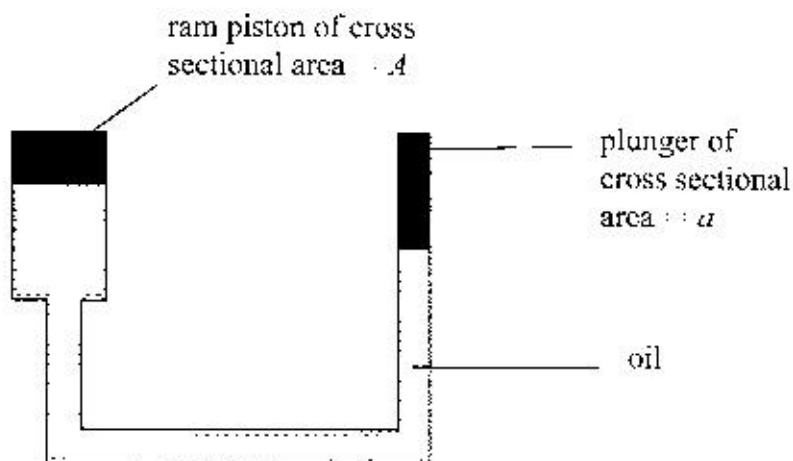

Figure 12

- When the Plunger moves down a distance d the Ram piston moves up a distance D .
Derive an expression for the Velocity Ratio (V.R.) in terms of A and a . (4 marks)

.....

.....

.....

.....

.....

.....

.....

.....

.....

- (c) A machine of velocity ratio 45 overcomes a load of $4.5 \times 10^3 \text{ N}$ when an effort of 135 N is applied. Determine:

- (i) the mechanical advantage (M.A) of the machine; (2 marks)

.....

.....

(ii) efficiency of the machine;

(2 marks)

(iii) the percentage of the work that goes to waste.

(1 mark)

17. (a) When a bus goes round a bend on a flat road, it experiences a centripetal force. State what provides the centripetal force.

(1 mark)

(b) State the purpose of banking roads at bends.

(2 marks)

- (c) A student whirls a stone of mass 0.2 Kg tied to string of length 0.4 m in a vertical plane at a constant speed of 2 revolutions per second. (Take acceleration due to gravity, $g = 10 \text{ ms}^{-2}$).

- (i) State **two** forces acting on the stone when it is at the highest point. (2 marks)

.....

.....

.....

.....

.....

- (ii) Determine the:

- I. Angular velocity of the stone. (3 marks)

.....

.....

.....

.....

.....

- II. Tension in the string when the stone is at the highest point. (3 marks)

.....

.....

.....

.....

.....

18. (a) State Newton's first law of motion.

(1 mark)

.....

.....

.....

.....

.....

.....

.....

.....

- (b) A wooden block resting on a horizontal bench is given an initial velocity, u , so that it slides on the bench surface for a distance, d , before coming to a stop. The values of d were measured and recorded for various values of initial velocity. Figure 13 shows the graph of u^2 against d .

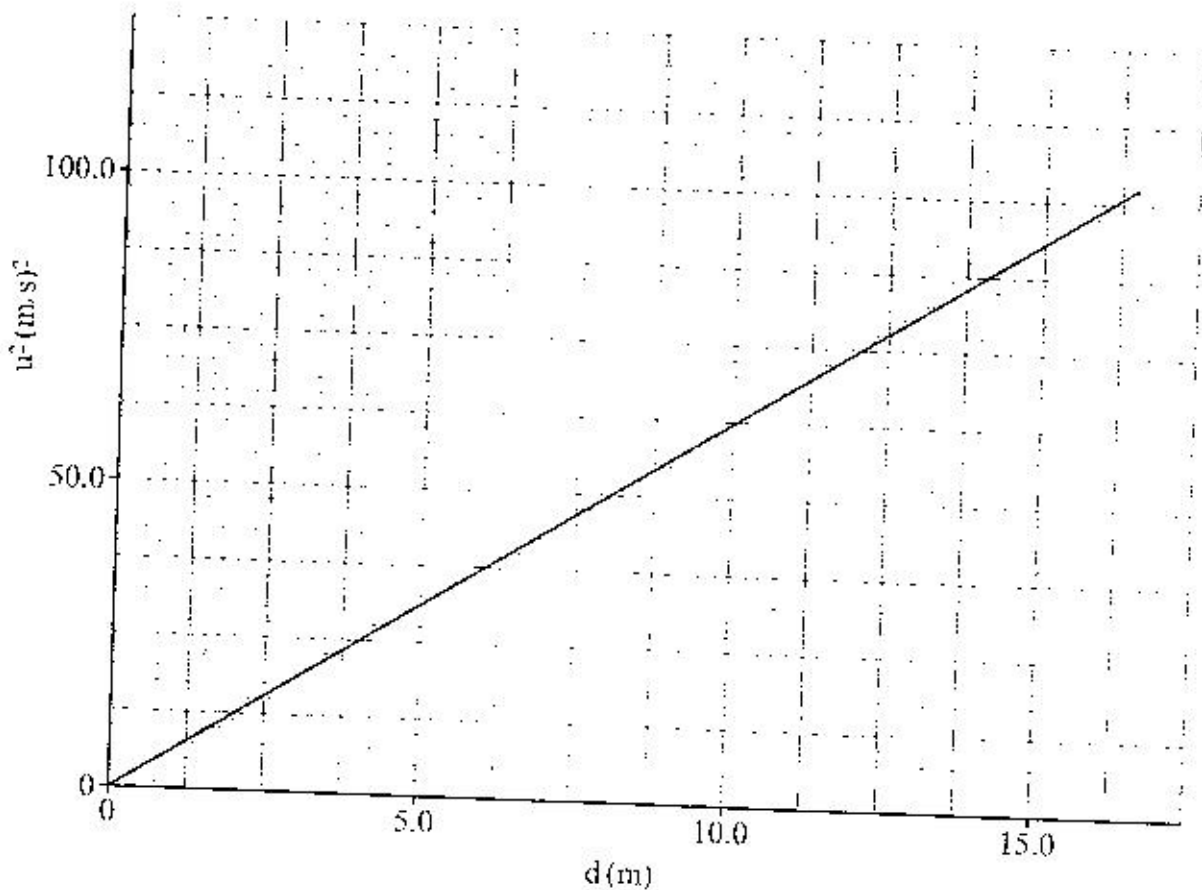

Figure 13

- (i) Determine the slope, s , of the graph. (2 marks)

.....

.....

.....

.....

.....

- (ii) Given that $U^2 = 20kd$, where k is constant for the bench surface, determine the value of k from the graph. (2 marks)

.....

.....

.....

.....

.....

- (c) A car of mass 800 Kg starts from rest and accelerates at 1.2 ms^{-2} . Determine its momentum after it has moved 400 m from the starting point. (3 marks)

.....

.....

.....

.....

.....

.....

.....

.....

.....



THIS IS THE LAST PRINTED PAGE.