

2207/302

TELECOMMUNICATION PRINCIPLES

Oct./Nov. 2009

Time: 3 hours

THE KENYA NATIONAL EXAMINATIONS COUNCIL

DIPLOMA IN AERONAUTICAL ENGINEERING AVIONICS
(COMMUNICATION AND NAVIGATION OPTION)

TELECOMMUNICATION PRINCIPLES

3 hours

INSTRUCTIONS TO CANDIDATES

You should have the following for this examination:

Answer booklet

Mathematical tables/Calculator

Drawing instruments.

Answer any FIVE of the EIGHT questions in this paper.

All questions carry equal marks.

This paper consists of 7 printed pages.

Candidates should check the question paper to ascertain that all the pages are printed as indicated and that no questions are missing.

1. (a) (i) Define the following as applied to filter networks:

- I. passband;
- II. cutoff frequency.

(ii) For the low-pass filter circuit of figure 1 determine the following:

- I. cutoff frequency;
- II. nominal impedance.

(6 marks)

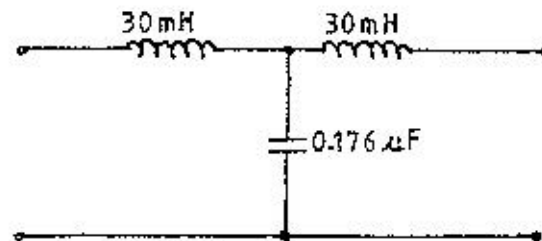

Figure 1

(b) With the aid of an electrical equivalent circuit diagram, explain how resonance occurs in a piezoelectric crystal hence sketch its response curve.

(6 marks)

(c) For the astable multivibrator of figure 2, determine from first principles the following:

- (i) pulse repetition frequency;
- (ii) mark-to-space ratio of the output waveform.

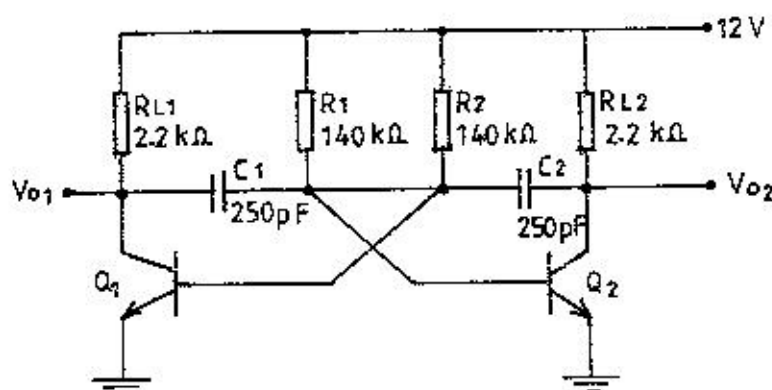

Figure 2

(8 marks)

2. (a) (i) State any one application of relays.

(ii) With the aid of a labelled diagram, explain the principle of operation of a drag-cup generator.

(7 marks)

(b) Show that the speed, N , of a d.c. motor is given by expression:

$$N = \frac{V}{k\Phi}$$

where V = terminal voltage

Φ = useful flux per pole

k = a constant

(6 marks)

(c) For the silicon controlled rectifier (SCR) trigger circuit of figure 3, determine the range of values of resistor R_1 that will ensure the unijunction transistor (UJT) fires and turns off given the following UJT parameters:

intrinsic stand-off ratio	η	=	0.5
valley voltage	V_V	=	1V
valley current	I_V	=	10mA
peak current	I_P	=	10 μ A
interbase resistance	R_{BB}	=	5K Ω
interbase voltage	V_{BB}	=	25 V
emitter diode drop	V_D	=	0.6V

(7 marks)

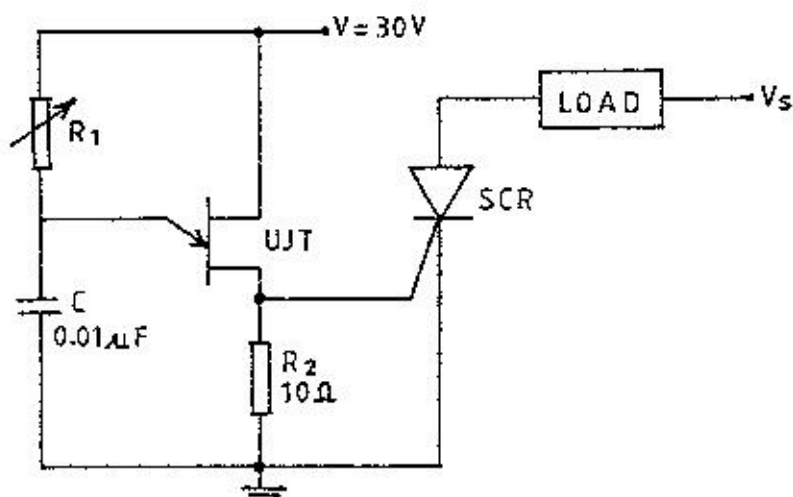

Figure 3

3. (a) (i) Define the following as applied to frequency modulation (FM):
- I. frequency deviation;
 - II. modulation index.
- (ii) Compare and contrast any two performance characteristics of Foster-seeley discriminator and ratio detector in FM systems. (6 marks)
- (b) Sketch the response curve of an FM amplitude limiter and explain its shape. (4 marks)
- (c) A 4V, 95 MHz carrier is frequency modulated by a 200Hz audio sine wave. If the maximum deviation is 10kHz:
- (i) obtain the expression for the instantaneous voltage of the modulated wave;
 - (ii) determine the power dissipated in a 20Ω resistor by the modulated wave. (10 marks)
4. (a) (i) Draw the h-parameter equivalent circuit for the emitter follower amplifier of figure 4 ignoring h_{oe} and h_{re} .
- (ii) From the equivalent circuit in a (i) determine the input impedance of the amplifier given that the transistor has $h_{ie} = 1k\Omega$ and $h_{fe} = 50$. (8 marks)

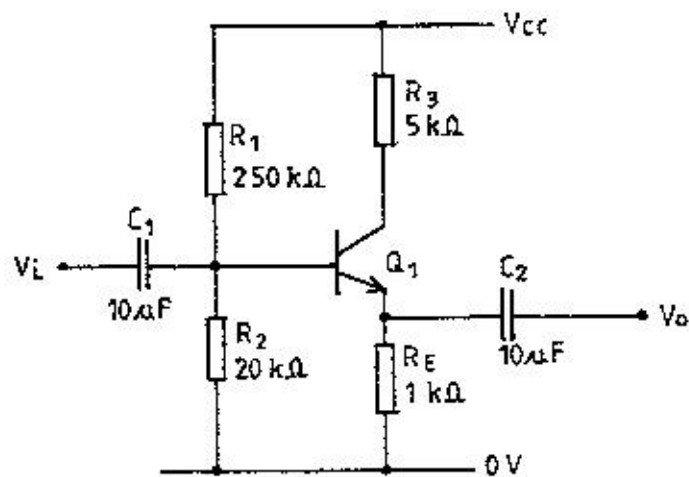

Figure 4

- (b) A transistor used in a single-ended transformer - coupled class A amplifier has the data given in table 1. Given the load resistor $R_L = 5\Omega$, transformer turns ratio $n = 3.464:1$, supply voltage $V_{cc} = 20V$ and the quiescent base bias current $I_{bq} = 10mA$:

- (i) plot the characteristic curves;
- (ii) draw the dc load line;
- (iii) draw the ac load line;
- (iv) determine the power dissipated in the load resistor.

(12 marks)

Table 1

V_{ce} (V)	I_c (A)				
	$I_b = 2mA$	$I_b = 6mA$	$I_b = 10mA$	$I_b = 14mA$	$I_b = 18mA$
1	0.02	0.22	0.40	0.60	0.80
40	0.20	0.40	0.60	0.80	1.00

5. (a) (i) State any two areas of application of wide band amplifiers.
- (ii) With the aid of a circuit diagram, explain unilaterization of tuned radio frequency amplifiers. (8 marks)
- (b) (i) Derive the expression for the voltage gain with feedback for the feedback amplifier of figure 5 where A = gain without feedback
 β = feedback factor.
- (ii) Show that the voltage gain obtained in b (i) depends only on the feedback network assuming the loop gain is far much greater than unity. (6 marks)

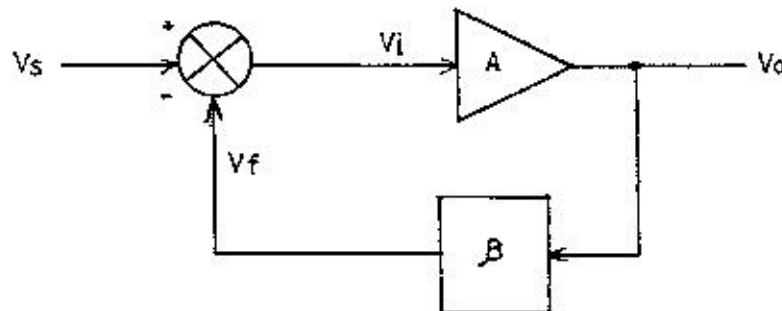

Figure 5

- (c) An amplifier has a gain $A = 100$, input resistance $R_i = 2K\Omega$ and output resistance $R_o = 40K\Omega$. If voltage series negative feedback is applied with $\beta = 0.1$, determine the following:
- (i) gain;
 - (ii) input resistance;
 - (iii) output resistance. (6 marks)

6. (a) (i) State with reasons why the amplitude of the modulating signal must not be greater than that of the carrier in amplitude modulation (AM) systems.
- (ii) Show that amplitude modulation will occur if the carrier and modulating signals are applied in series to a non linear device. (9 marks)

- (b) (i) State the sampling theorem as applied to pulse modulation.
- (ii) Explain the effects of noise on a pulse-width modulated wave and how these effects can be minimised. (6 marks)

- (c) The tuned circuit of the oscillator in an AM transmitter employs a $75\mu H$ coil and a $1nF$ capacitor. If the oscillator is amplitude modulated by audio frequencies upto $2kHz$ determine the:
- (i) lower side frequency;
 - (ii) upper side frequency;
 - (iii) bandwidth of the transmitted signal. (5 marks)

7. (a) (i) Define the following as applied to propagation of radio waves:
- I. refraction;
 - II. diffraction.
- (ii) With the aid of a wavefront diagram, describe propagation of ground waves. (9 marks)

- (b) A single-hop transmission between two points $1500km$ apart employs a maximum usable frequency of $35MHz$. If the height of the ionosphere is $350km$, determine the critical frequency. (4 marks)

- (c) A 225m high transmitting antenna operating at 2MHz with antenna current of 6A is 76km away from a receiving antenna.

Determine the:

- (i) height of the receiving antenna;
- (ii) voltage induced in the receiving antenna.

(7 marks)

8. (a) (i) Define the following as applied to transmission lines:

- I. standing wave ratio;
- II. propagation constant.

- (ii) Explain the effects of the following transmission line terminations on a transmitted wave:

- I. open circuit;
- II. short circuit.

(6 marks)

- (b) Sketch the curve illustrating the variation of the characteristic impedance of a transmission line with the signal frequency hence explain its shape.

(6 marks)

- (c) A transmission line having negligible losses has primary constants of $L = 0.5\text{mH/km}$ and $C = 0.12\mu\text{F/km}$. If the line is operating at 400kHz, determine the:

- (i) characteristic impedance;
- (ii) propagation coefficient;
- (iii) wavelength of the line;
- (iv) velocity of propagation.

(8 marks)