

Name .....

Class .....

231/ 2  
BIOLOGY  
Paper 2  
(Theory)  
March 2017  
2 hours

Adm No.....

Sunshine Secondary School  
Kenya Certificate of Secondary Education  
PRE-MOCK ONE, 2017

*Instructions to candidates*

*Write your name and class in the spaces provided above.*

*This paper consists of two sections: A and B.*

*Answer ALL the questions in section A in the spaces provided.*

*In section B answer question 6 (compulsory) and either question 7 or question 8 in the spaces provided after question 8*

**For Examiner's Use Only**

Section	Question	Maximum Score	Candidate's Score
A	1	8	
	2	8	
	3	8	
	4	8	
	5	8	
B	6	20	
		20	
Total Score		80	

1. A man with normal colour vision marries a colour blind woman. The first children were daughters all with normal colour vision. The two sons were colour blind.

(a)(i) State the location of the gene for colour vision.....(1 mark)

ii) Using a punnet square, work out the possible genotypes of their children. Use B to represent the gene for normal colour vision (4 marks)

(b) Name another trait in humans inherited in the same way .....(1 mark)

(c) Explain one importance of genetic counseling (1 mark)

.....  
.....

(d) State two causes of mutation in man (1 mark)

.....  
.....

2. Pea seedlings were treated as follows:

Seedling A - Coleoptile tip was cut off, metal block placed, then tip placed back

Seedling B – Coleoptile tip was cut off, agar block placed then tip placed back

Seedling C – was left intact

The seedlings A, B and C were placed in a dark box with a small hole at one side as illustrated in the diagram below.

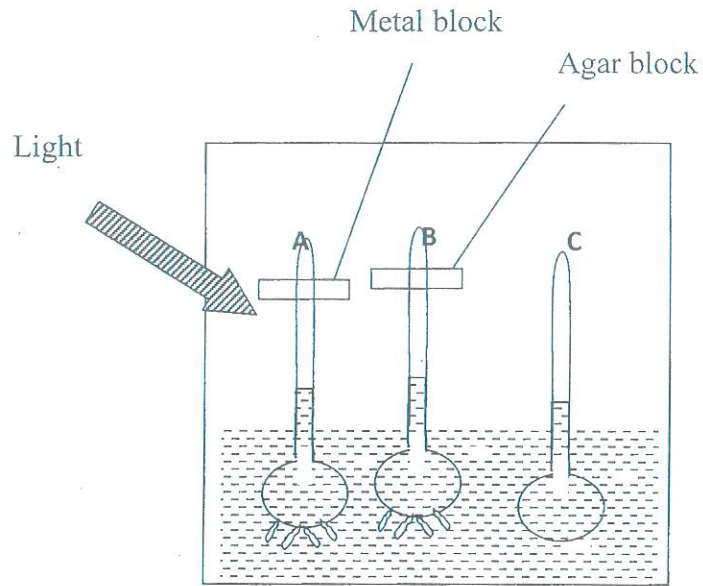

(a) State what was being investigated in the set up above ( 2 marks)

- (i) .....
- (ii) .....

(b) Using diagrams illustrate how the seedlings A and B appear after 48 hours? (2 marks)

(c) Explain the results in b) above  
Seedling A (1 mark)

- .....
- .....

.....  
.....

Seedling **B**

(2 marks)

.....  
.....  
.....

(d) Explain why seedling **C** was included in the set up

(1 Mark)

.....  
.....  
.....

3. Below is a set up showing a certain physiological process

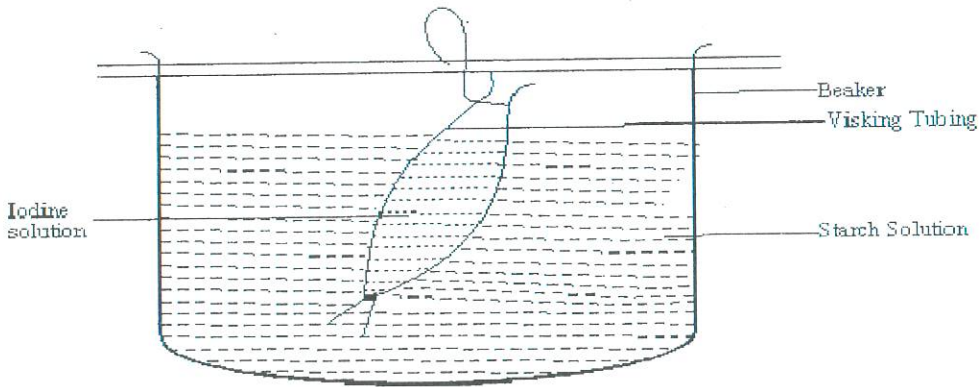

(a) Identify the process .....( 1mark)

(b) Explain the observation made after 10 minutes (4 marks)

.....  
.....

.....  
.....

(c) Outline **3 roles** of active transport in the human body (3 marks)

.....  
.....  
.....

4. The following is an illustration showing a blood vessel. Study it then answer the questions below.

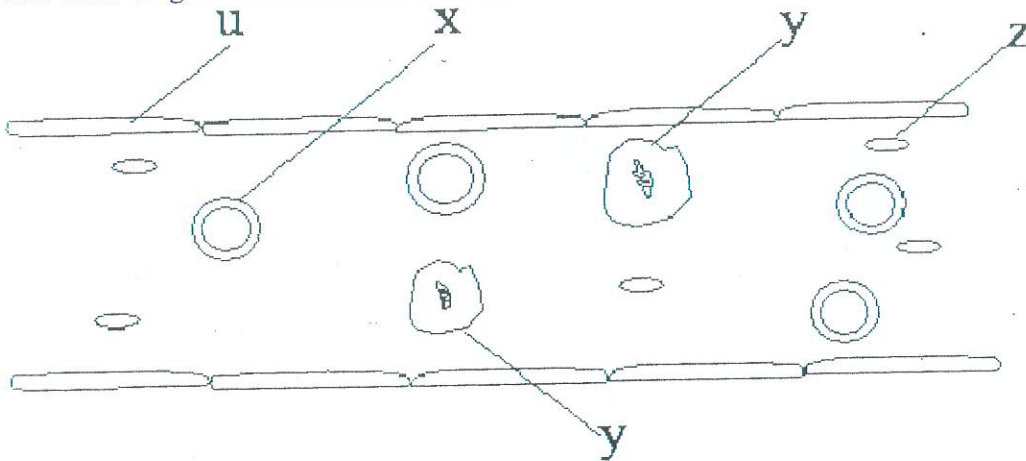

(a) Identify the blood vessel.....(1 mark)

(b) How is the blood vessel named in (a) above adapted to its functions. (2 marks)

.....  
.....

(c) Name the cells labeled **X**, **Y** and **U** (3 marks)

X..... U.....

Y.....

(d) State the function of the cell labeled **Z** (1 Mark)

.....



.....  
.....  
(e) Name the fluid in which cells X, Y and Z are suspended

(1 mark)

5. The diagram below shows the relationship between four hormones involved in menstrual cycle.

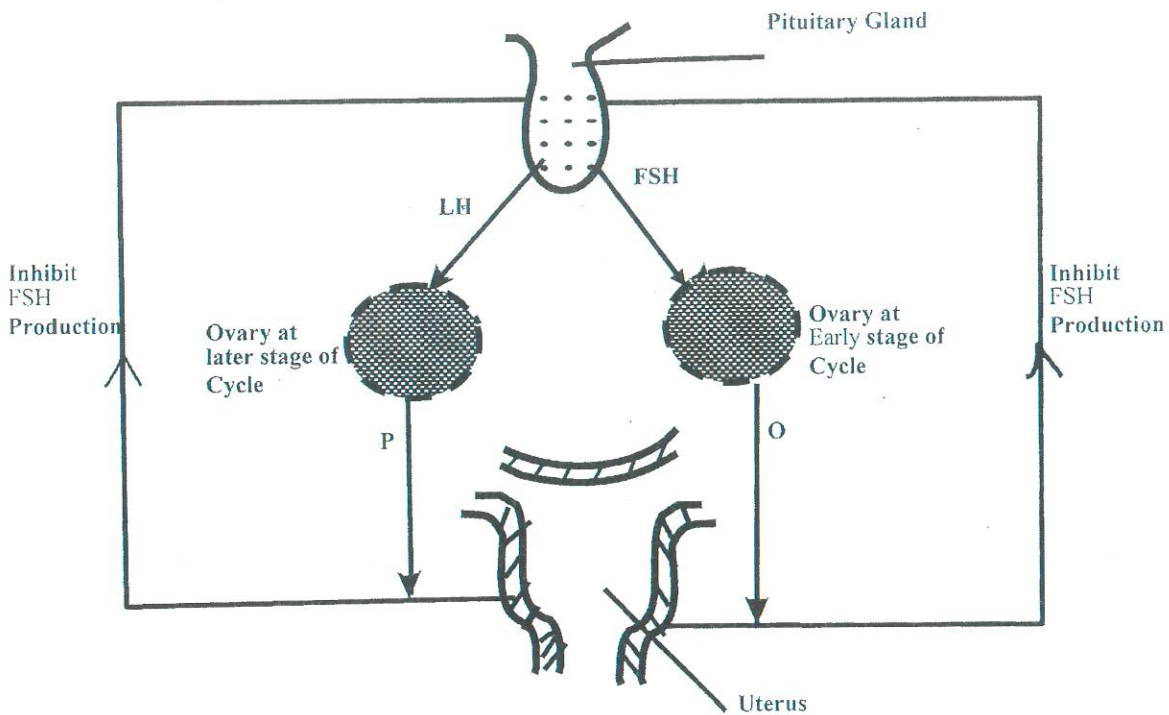

Key:

FSH – follicle stimulating hormone

LH – Leutenising hormone

O – Oestrogen

P – Progestrone

(a) Both Oestrogen and progesterone affect the uterus during the menstrual cycle. State the effects each has on t he uterus (2 marks)

(i) Oestrogen

.....  
.....

(ii) Progesterone

.....

.....

(b) What effects does FSH have on the early stage of the menstrual cycle (2 marks)

.....

.....

.....

(c) Where in the ovary is progesterone formed?.....(1 mark)

(d) One type of contraceptive pill contains both oestrogen and progesterone. Explain briefly how such pills prevent conception. (1 mark)

.....

.....

.....

.....

(e) Where else is the hormone progesterone produced and at what time? (2 marks)

.....

.....

6. A group of students investigated the relationship between the rainfall pattern in a terrestrial ecosystem and the population of the two animal species M and P for one year. The results for the rainfall recorded monthly were plotted in the bar graph below while the animal population were recorded in the table below.

rainfall  
mm

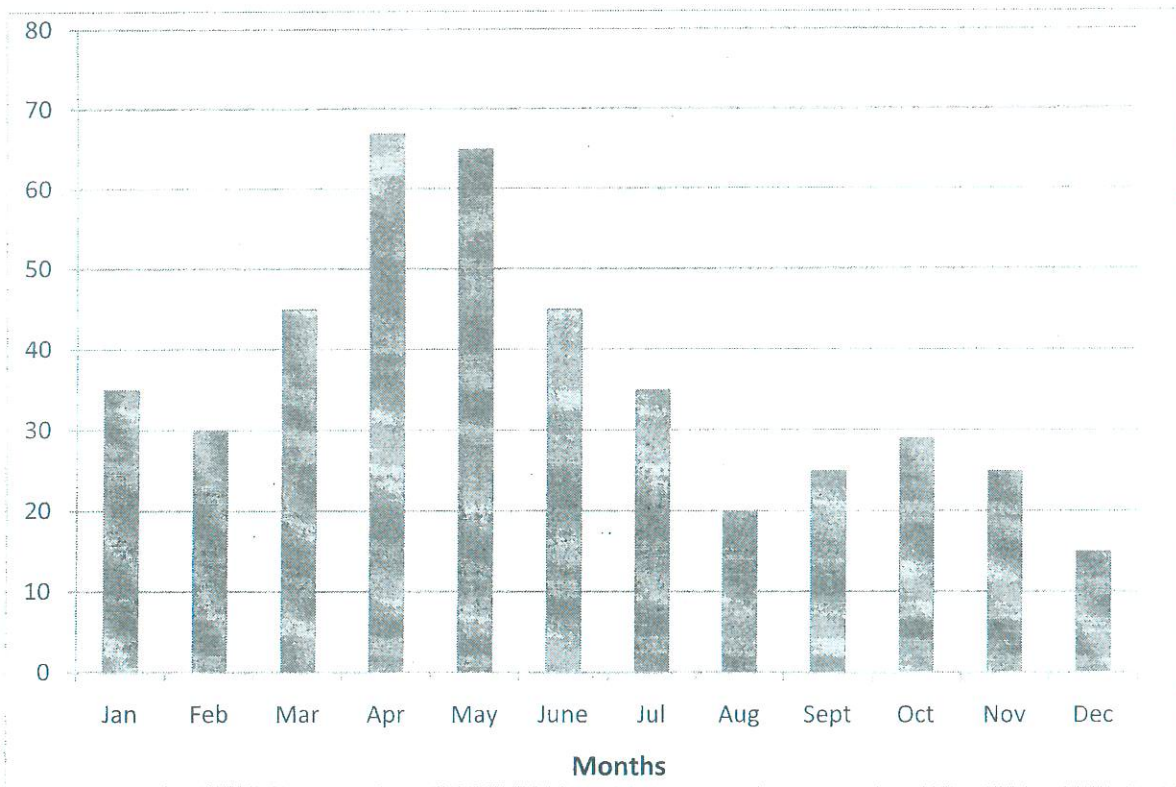

Month	J	F	M	A	M	J	J	A	S	O	N	D
Population of species N	600	350	500	1200	1800	1700	1200	650	450	710	1300	1200
Population of species P	810	400	120	320	790	1220	1420	1000	520	200	400	880

(a) Using appropriate scale, plot two curves of animal species populations against time, on the same Axis. (8 marks)



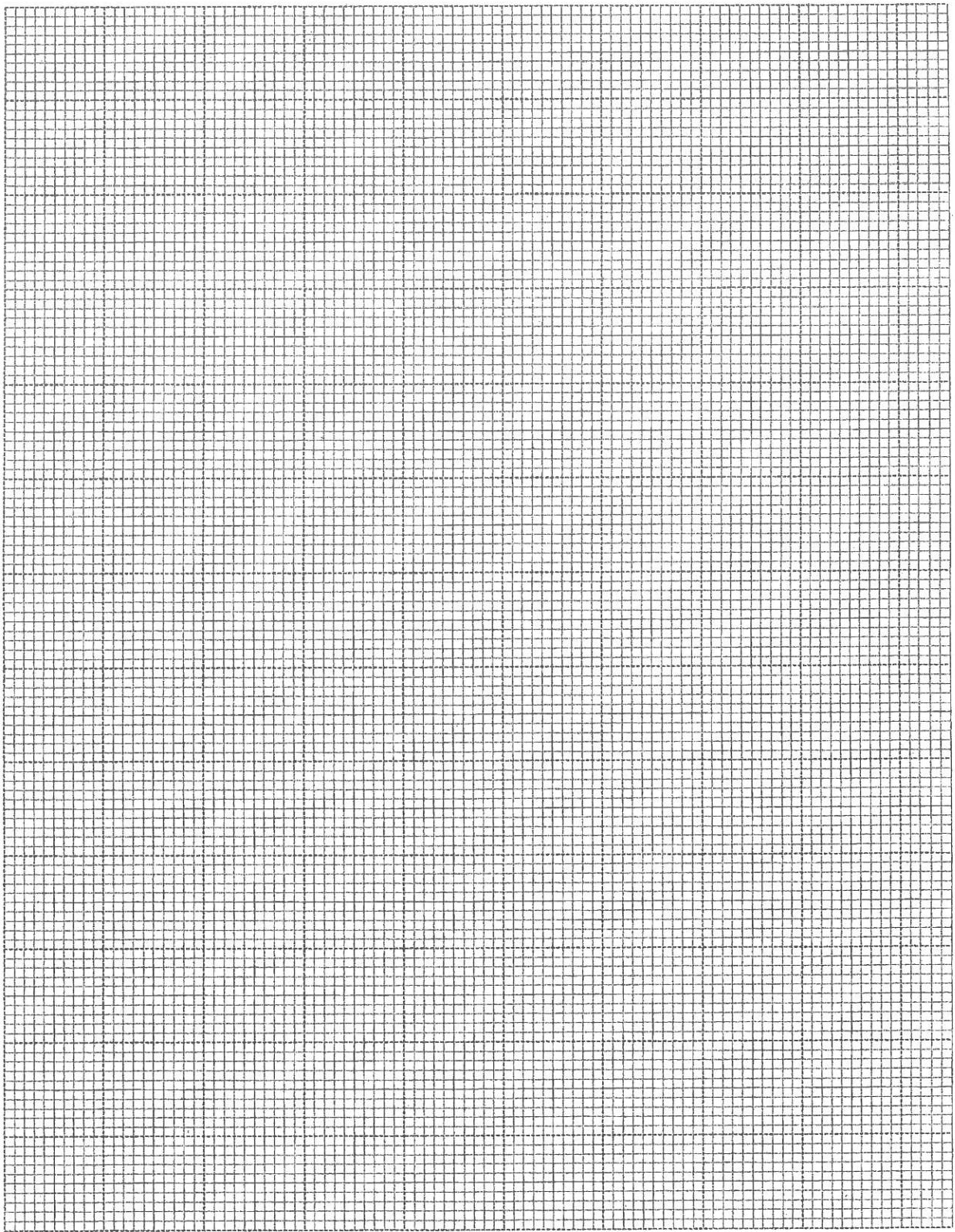

(b)(i) What is the relationship between rainfall pattern and changes in the population of species N? (2 marks)

.....  
.....

(ii) Account for the relationship in (i) above (2 marks)

.....  
.....

(c)(i) What is the feeding relationship between P and N if they belong to the same food chain (2mark)

.....  
.....  
.....  
.....

(ii) Account for the changes in population of species P during the months of July and October (4marks)

.....  
.....  
.....  
.....  
.....  
.....

(d) If in the same year animal species N immigrated into the same habitat how would this affect the population of:-

i) N

ii P



