

Name Class.....
 Index Number:...../.....Signature.....Date.....

121/2

PRE-MOCK

Kenya Certificate of Secondary Education

MATHEMATICS

PAPER 2

2 ½ HOURS

Instructions to candidates

- Write your name, index number, admission number and class in the spaces provided above.
- Sign and write the date of examination in the spaces provided above.
- The paper contains **TWO** sections: **Section I** and **Section II**.
- Answer **ALL** the questions in **Section I** and any **five** questions from **Section II**
- All answers and working must be written on the question paper in the spaces provided below each question.
- Show all the steps in your calculations, giving your answers at each stage in the spaces below each question.
- Non – programmable silent electronic calculators and KNEC Mathematical tables may be used, except where stated otherwise.

For Examiner's use only

Section I

1	2	3	4	5	6	7	8	9	10	11	12	13	14	15	16	Total

Section II

17	18	19	20	21	22	23	24	Total

Grand Total

--

This paper consists of 18 printed pages. Candidates should check the question paper to ascertain that all the pages are printed as indicated and no questions are missing.

SECTION I (50 MARKS)

Answer all questions in this section in the space provided

1. In an experiment to determine a local value of acceleration of free fall, g , a student made **11% error** and **2.5% error** in measuring length, l , and computing periodic time, T , respectively of a pendulum. He also made a **2% error** in approximating the value of π .

a) If $g = \frac{4\pi^2 l}{T^2}$, calculate the percentage error in obtaining g . (2 marks)

- b) If he obtained g as 7.84 ms^{-2} , determine the range in which the correct value of g lie. (2 marks)

2. If $p = 5 + \sqrt{2}$ and $q = 3 - 4\sqrt{2}$, find the value of $\frac{q}{p+q}$ in the form $a + b\sqrt{c}$ where a , b and c are rational numbers. (3 marks)

3. The figure below shows a semi-circle centre O with a tangent meeting it at point C . Angle $ECD = 40^\circ$, $AB = AE$. Calculate angle AEC giving reasons. (3 marks)

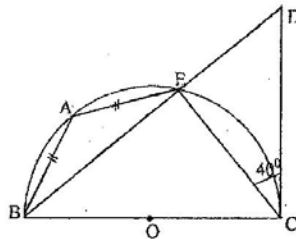

7.

A man deposits sh. 500,000 in an investment which pays 12% per annum interest compounded quarterly per year. Find how many years it takes for the money to double. (3 marks)

8.

Find the quartile deviation of the following data:
10, 2, 7, 5, 9, 6, 12, 4, 6, 3, 7, 8.

(3 marks)

9.

Two equal unbiased dice are tossed simultaneously. Calculate the probability that the sum of 10 or more will be thrown. (2marks)

4. Walpi and Walba are rice traders. They buy Pishori and Basmati rice brands and mix them in the ratios 2:3 and 3:5 respectively. Bi Wali bought 1kg of rice from Walpi and 2kg from Walba and mixed them. Find the ratio of Pishori to Basmati rice in Bi Wali's mixture. **(3 marks)**
5. In triangle ABC, angle BAC = 70° , AB = 9cm and BC = 11 cm. Find the area of the triangle. **(3 marks)**
6. The fifth term of an arithmetic progression is 11 and the twenty fifth term is 51. Find the first term and common difference of the progression. **(2 marks)**

10. A triangle ABC whose area is 4cm^2 is mapped onto triangle $A'B'C'$ whose area is 64cm^2 under a transformation matrix $\begin{pmatrix} 3+n & 3 \\ -2 & n \end{pmatrix}$.
- (a) Calculate the possible values of n . (2 marks)

- (b) Find the image of A (3, 4) under the above matrix transformation where $n < 0$. (2 marks)

11. The gradient of the of the curve $y = ax^2 + bx$ at the origin is equal to 8. Find the value of a and b if the curve has a maximum turning point at $x = 4$ (4marks)

- 12.(a) Expand and simplify $(2 - x)^5$ in ascending powers of x up to and including the term in x^3 . (2 marks)

- (b) Hence, approximate the value of 1.98^5 to 4 significant figures. (2 marks)

13. Using a pair compasses and ruler only, construct the loci of the points P, on which AB subtends a constant angle of 60° , given that $AB = 6\text{cm}$ and P is above AB. (3 marks)

14. Make t the subject of the formula.

$$2a = \sqrt{\frac{t^2 + q}{p^2}}$$

(3 marks)

15. Find the equation of a circle whose diameter is from point $(-2, 5)$ to point $(4, 1)$ in the form $x^2 + y^2 + ax + by + c = 0$ (4 marks)

16. Given that $a^2x^2 + 6ax + k$ is a perfect square, find k . (3 marks)

SECTION II (50 marks)

Answer any **FIVE** questions in this section in the spaces provided.

17.(a) Complete the table below, giving your values correct to 2 decimal places. **(2 marks)**

x°	0	15	30	45	60	75	90	105	120	135	150	165	180	195	210
$3\sin x^\circ - 1$	1		0.5	1.12		1.90		1.90	1.60		0.50				
$\cos x^\circ$	1		0.87		0.50	1.26	0.00								

Using the grid provided below, draw on the same axes, the graphs of $y = 3 \sin x^\circ - 1$ and $y = \cos x^\circ$ for $0^\circ \leq x \leq 210^\circ$. (Take the scale of 1cm to 15° on the horizontal axis 2cm for 1 unit on the vertical axis.

(5 marks)

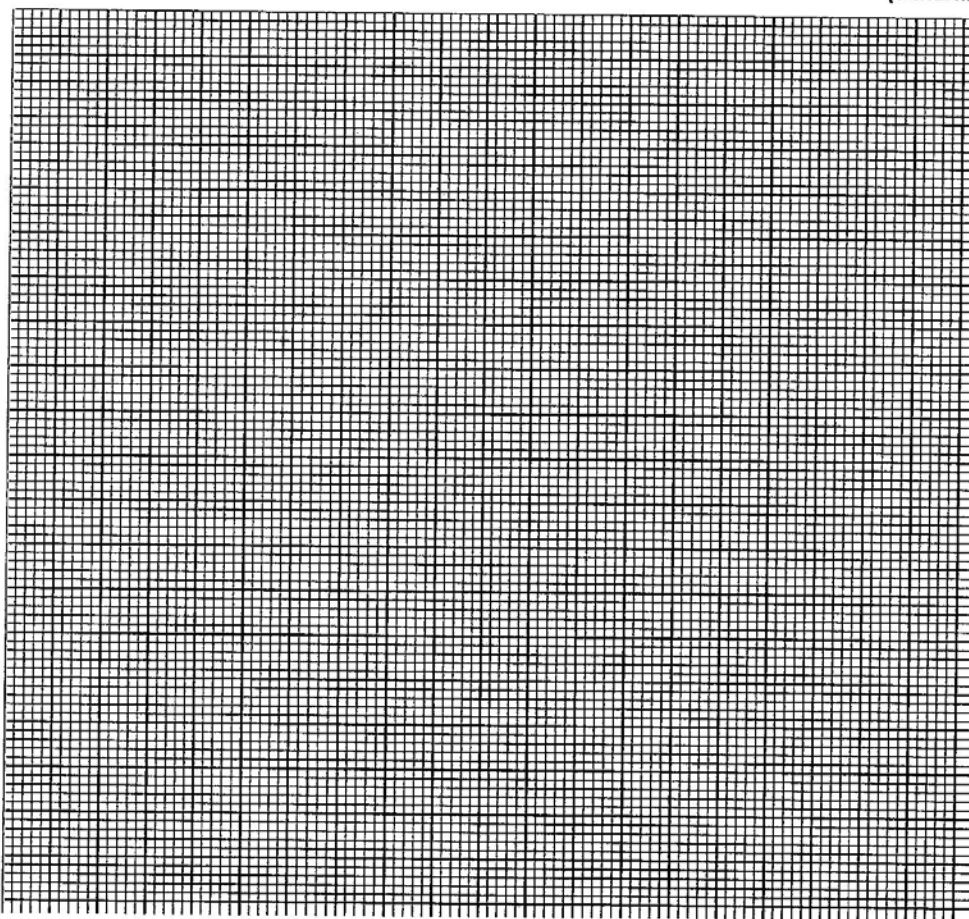

- (b)** Using your graph,
- (i) give the solutions to the equation $3 \sin x^\circ - \cos x^\circ = 1$ **(2 marks)**
- (ii) Amplitude of the curve $y = 3 \sin x^\circ - 1$ **(1 mark)**

18. The diagram below shows a sketch of the line $y = 3x$ and the curve $y = 4 - x^2$ intersecting at points P and Q.

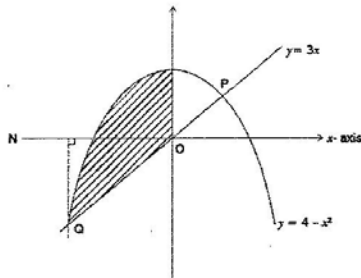

- (a) Find the coordinates of P and Q. (3 marks)
- (b) Given that QN is perpendicular to the x -axis at N, calculate:
- (i) The area bound by the curve $y = 4 - x^2$, the line QN and the x -axis. (3 marks)
- (ii) The area of the shaded region that lies below the x -axis. (2 marks)
- (iii) The area of the shaded region enclosed by the curve $y = 4 - x^2$, the line $y = 3x$ and the y -axis. (2 marks)

19. An aeroplane flies from point A ($1^{\circ} 15'S, 37^{\circ} E$) to a point B directly North of A. The arc AB subtends an angle of 45° at the centre of the earth. From B, the aeroplane flies due west to a point C on longitude $23^{\circ} W$.

Taking the value of $\pi = \frac{22}{7}$ and radius of the earth as 6370km;

- (a) (i) Find the latitude of B. (3marks)

- (ii) Find the distance travelled by the aeroplane between B and C in km and in nm. (4marks)

- (b) The aeroplane left B on Wednesday at 1.00a.m local time. When the aeroplane was leaving B, what was the local time at C? (3marks)

20. A company wishes to install two types of packaging machines; X and Y for its Maji Ni Uhai project. Machine Y requires four attendants whereas machine X one requires two. Machine X fills 300 packets per hour while Y fills 200 packets per hour. At least 3000 packets need to be filled per hour and the number of attendants should not exceed 40.

a) Write down inequalities to describe these conditions and graph them.

(6marks)

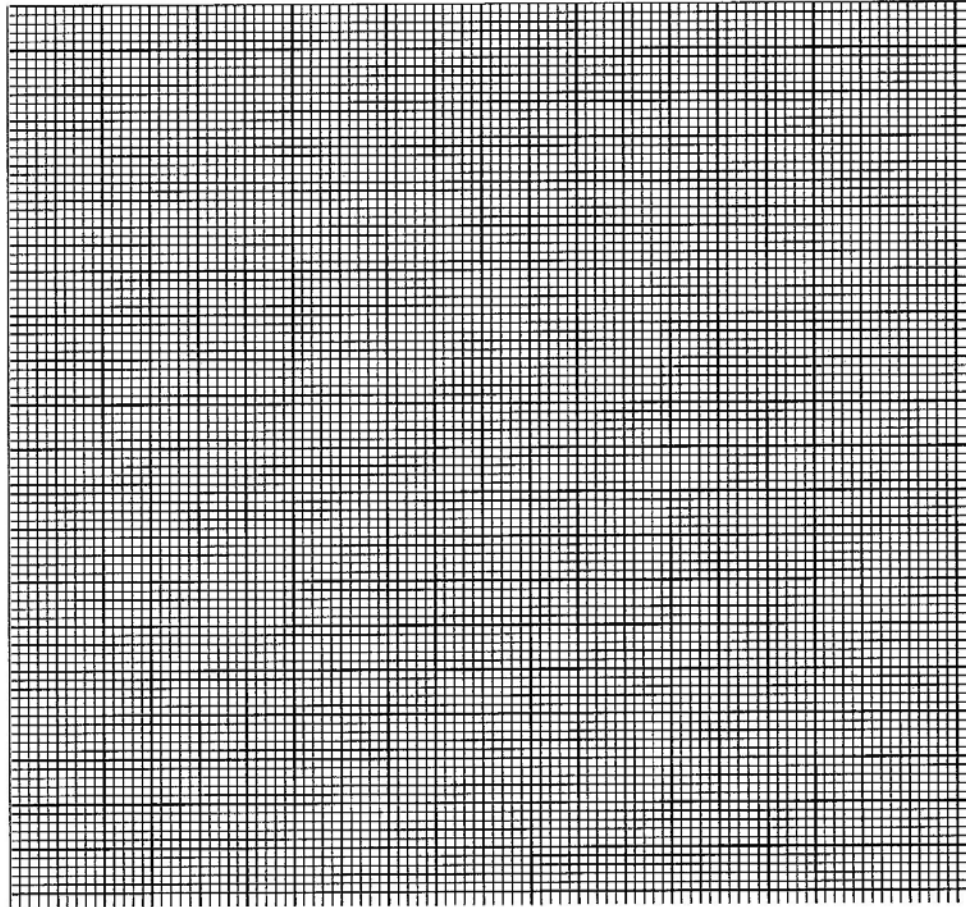

b) If for every hour it is used, an electric machine brings a profit of Kshs 200 and a manual one Kshs 500, determine the number of machines of each type that should be installed in order to maximize profit per hour.

(2marks)

c) Find the maximum profit.

(2mark)

21. a) In a form 4 class there are 22 girls and 18 boys. The probability that a girl completes secondary education course is $\frac{3}{5}$ whereas that of a boy is $\frac{2}{3}$. A student is picked at random from the class. Find the probability that the student picked:

(i) Is a boy and will complete the course. (2 marks)

(ii) Will complete the course. (2 marks)

(iii) Is a girl and will not complete the course. (2 marks)

(b) A bag contains 5 blue balls, 8 red balls and 3 green balls being similar in shape and size. A ball is picked out at random without replacement and its colour noted. Use a tree diagram to determine the probability that at least one of first two balls picked is green. (4 marks)

22. In a botanical experiment, the length of 60 leaves of a certain type of a tree were measured correct to the nearest 0.1 cm.

Length (cm)	3.0–3.4	3.5–3.9	4.0–4.4	4.5–4.9	5.0–5.4	5.5–5.9	6.0–6.4	6.5–6.9	7.0–7.4
No. of leaves	1	4	9	14	12	10	6	3	1

- a) State the modal frequency (1mark)
- b) Calculate the median length (3 marks)
- c) Using a working mean of 5.2 find;
- i) The mean (3marks)
- ii) The standard deviation (3marks)

23. An employee earns a basic salary of Ksh. 19,630, a house allowance of Ksh. 6,200 and a transport allowance Ksh x per month. She claims a personal relief of Ksh 1,080 per month. The income tax table used is as shown below.

Monthly income (K£)	Rate per K£ (Shs)
1-480	2
481-960	3
961-1440	5
1441-1920	7
1921-above	9

- a) If he paid a PAYE of sh 3233 per month, calculate her transport allowance **(5 marks)**

- b) If she pays Kshs 320 for NHIF, Kshs 500 towards a Co-op loan and Kshs 2,500 for Co-operative shares, find her net monthly salary. **(3 marks)**

- c) He decides to save $\frac{1}{6}$ of his basic salary to purchase a Motor bike. Calculate his saving per year. **(2 marks)**

24. The figure below shows a pulley system where a conveyor belt is tied round the two wheels. The radius of the larger wheel is 180cm and the distance between the centres of the wheels is 300cm and angle $AMC=140^\circ$.

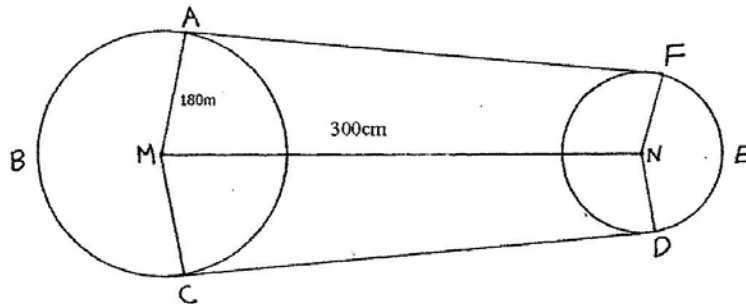

- (a) Determine the length AF (2marks)
- (b) the length of the arc FED (4marks)
- (c) the length of the arc ABC (2marks)
- (d) the total length of the conveyor belt (2marks)